

# 鋼管差込み溶接フランジ規格 (JISより抜粋)

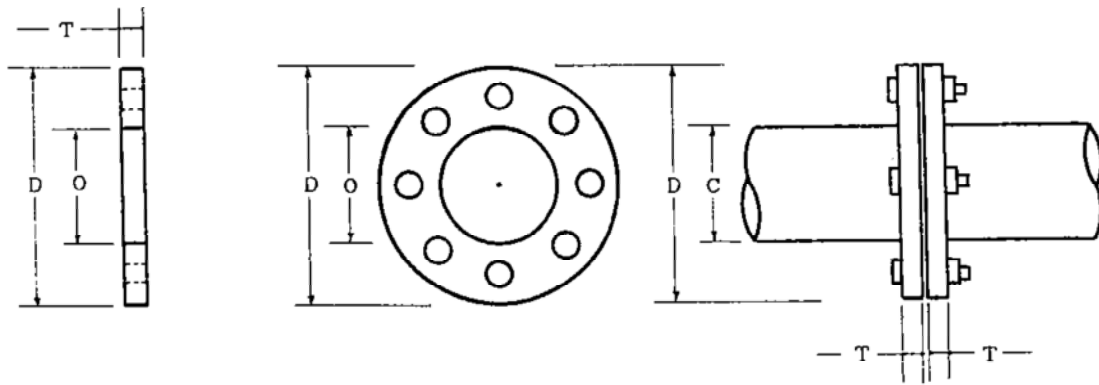

呼び管径	管外径 C	フランジ10K 溶接フランジ			5 K 溶接フランジ		摘要
		内径 O	D	T	D	T	
15A	21.7	22.2	95	12	80	9	
20A	27.2	27.2	100	14	85	10	
25A	34.0	34.5	125	14	95	10	
32A	42.7	43.2	135	16	115	12	
40A	48.6	49.1	140	16	120	12	
50A	60.5	61.1	155	16	130	14	
65A	76.3	77.0	175	18	155	14	
80A	89.1	90.0	185	18	180	14	
100A	114.3	115.4	210	18	200	16	
125A	139.8	141.2	250	20	235	16	
150A	165.2	116.6	280	22	265	18	
200A	216.3	218.0	330	22	320	20	
250A	267.4	269.5	400	24	385	20	
300A	318.5	321.0	445	24	430	22	
350A	355.6	358.1	490	26	480	22	
400A	406.4	409.0	560	28	540	24	
450A	457.2	460.0	620	30	605	24	